

<p>PLEASE NOTE Electrical equipment should be installed, operated, serviced, and maintained only by qualified personnel. No responsibility is assumed by Schneider Electric for any consequences arising out of the use of this material.</p>	<p>REMARQUE IMPORTANTE L'installation, l'utilisation, la réparation et la maintenance des équipements électriques doivent être assurées uniquement par du personnel qualifié. Schneider Electric décline toute responsabilité quant aux conséquences de l'utilisation de ce matériel.</p>	<p>TENGA EN CUENTA La instalación, manejo, puesta en servicio y mantenimiento de equipos eléctricos deberán ser realizados sólo por personal cualificado. Schneider Electric no se hace responsable de ninguna de las consecuencias del uso de este material.</p>	<p>BITTE BEACHTEN Elektrische Geräte dürfen nur von Fachpersonal installiert, betrieben, bedient und gewartet werden. Schneider Electric haftet nicht für Schäden, die durch die Verwendung dieses Materials entstehen.</p>
<p>NOTA Manutenzione, riparazione, installazione e uso delle apparecchiature elettriche si devono affidare solo a personale qualificato. Schneider Electric non si assume alcuna responsabilità per qualsiasi conseguenza derivante dall'uso di questo materiale.</p>	<p>NOTA A instalação, utilização e manutenção do equipamento eléctrico devem ser efectuadas exclusivamente por pessoal qualificado. A Schneider Electric não assume qualquer responsabilidade pelas consequências resultantes da utilização deste material.</p>	<p>请注意 电气设备的安装、操作、维修和维护工作仅限于合格人员执行。Schneider Electric 不承担由于使用本资料所引起的任何后果。</p>	<p>ОБРАТИТЕ ВНИМАНИЕ Установка, эксплуатация, ремонт и обслуживание электрического оборудования может выполняться только квалифицированными электриками. Компания Schneider Electric не несет никакой ответственности за любые возможные последствия использования данной документации.</p>

<p>⚠ DANGER / DANGER / PELIGRO / GEFAHR / PERICOLO / PERIGO / 危險 / ОПАСНОСТЬ</p>			
<p>HAZARD OF ELECTRIC SHOCK, EXPLOSION, OR ARC FLASH Disconnect all power before servicing equipment. Failure to follow these instructions will result in death or serious injury.</p>	<p>RISQUE D'ÉLECTROCUTION, D'EXPLOSION OU D'ECLAIR D'ARCO ELECTRIQUE Coupez toutes les alimentations avant de travailler sur cet appareil. Si ces directives ne sont pas respectées, cela entraînera la mort ou des blessures graves.</p>	<p>PELIGRO DE DESCARGA ELÉCTRICA, EXPLOSIÓN O ARCO ELECTRICO Desconecte todas las alimentaciones antes de manipular el producto. El incumplimiento de estas instrucciones podrá causar la muerte o lesiones serias.</p>	<p>GEFAHR VON ELEKTRISCHEM SCHLAG, EXPLOSION ODER LICHTBOGEN Vor dem Arbeiten am Gerät alle Spannungsversorgungen abschalten. Die Nichtbeachtung dieser Anweisungen führt zu Tod oder schweren Verletzungen.</p>
<p>RISCHIO DI FOLGORAZIONE, ESPLOSIONI O ARCO ELETTRICO Scollegare l'apparecchio da tutti i circuiti di alimentazione prima di qualsiasi intervento. Il mancato rispetto di queste istruzioni provocherà morte o gravi infortuni.</p>	<p>RISCO DE ELECTROCUSSÃO, DE EXPLOSIÃO, OU DE ARCO ELÉCTRICO Desconecte todas as alimentações antes de manipular o produto. A não observância destas instruções resultará em morte, ou ferimentos graves.</p>	<p>电击、爆炸或弧闪的危险 在此电力设备上工作时，请先切断所有电源，不遵循上述说明将导致人员伤亡。</p>	<p>Опасность поражения электрическим током, взрыва или возникновения дуги Перед обслуживанием или ремонтом убедитесь, что питание отключено. Несоблюдение этих инструкций приведет к смерти или серьезной травме.</p>

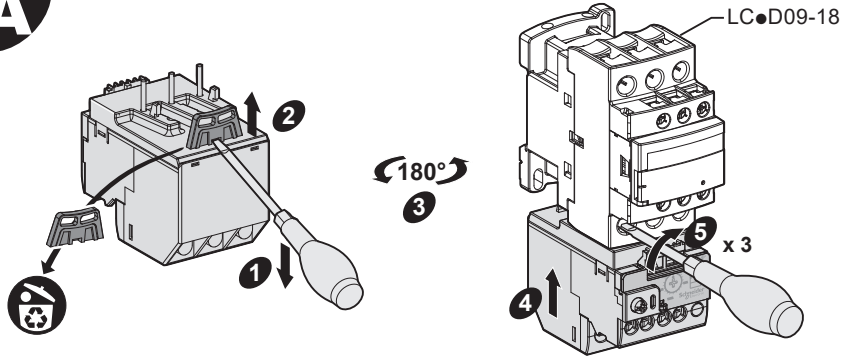

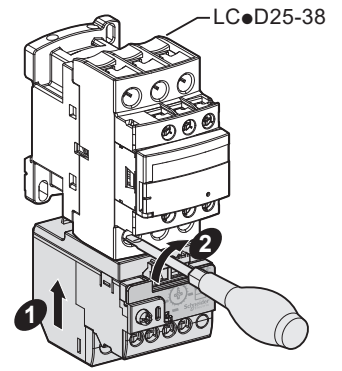

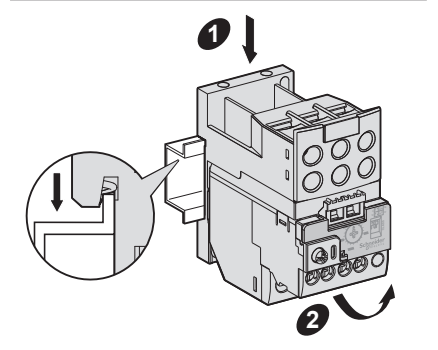
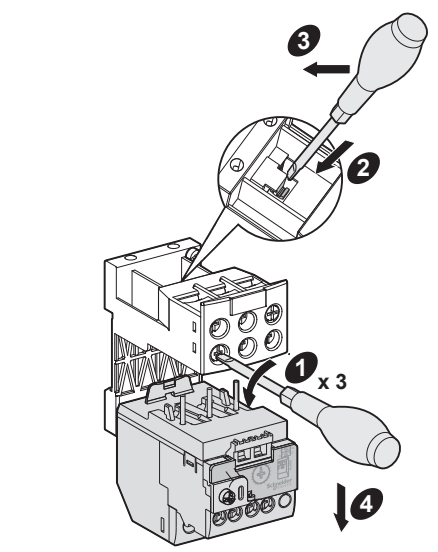
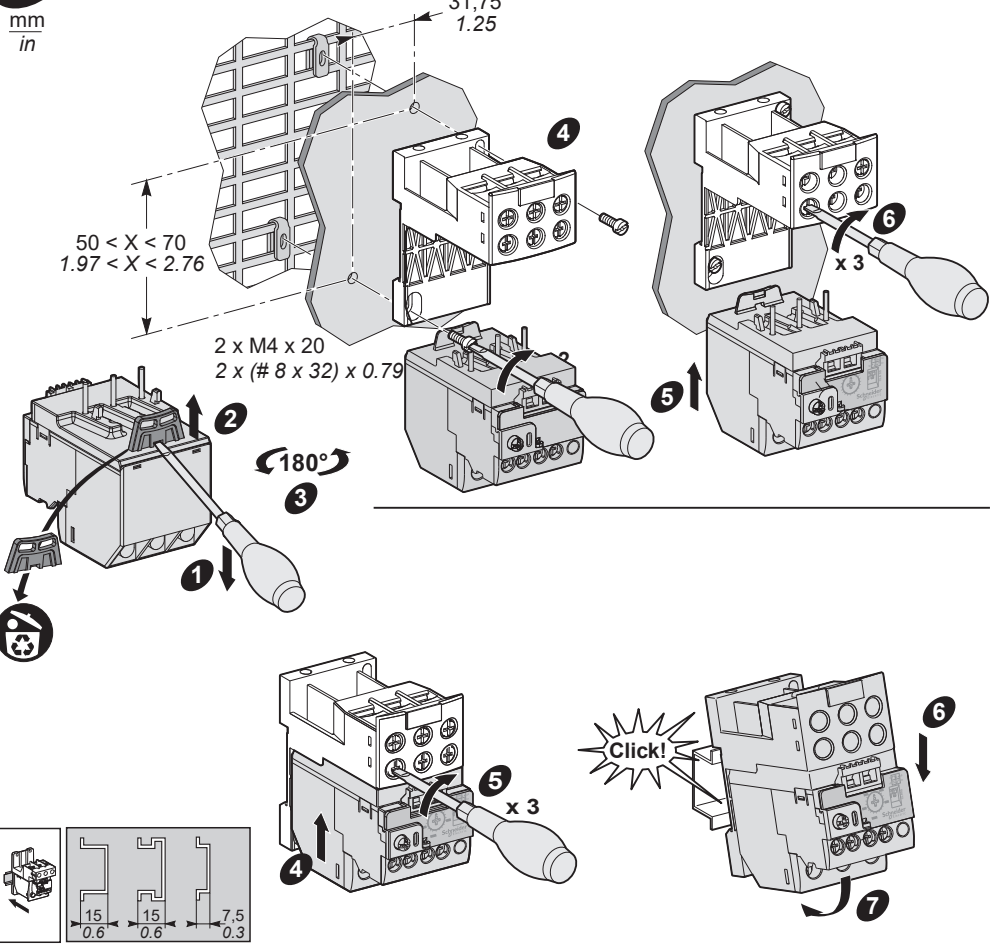

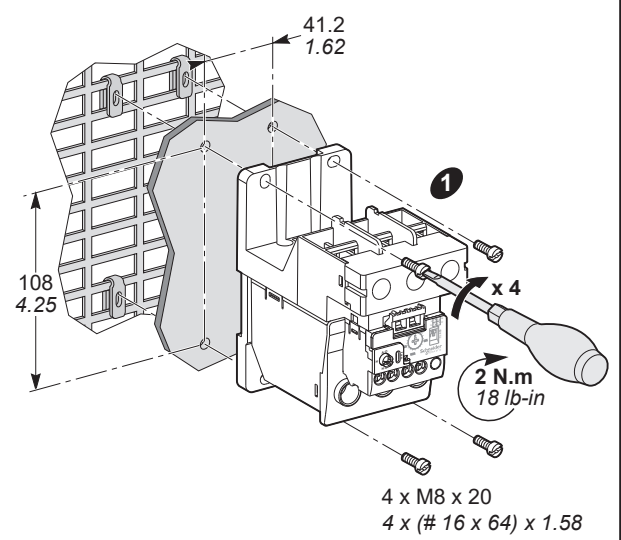
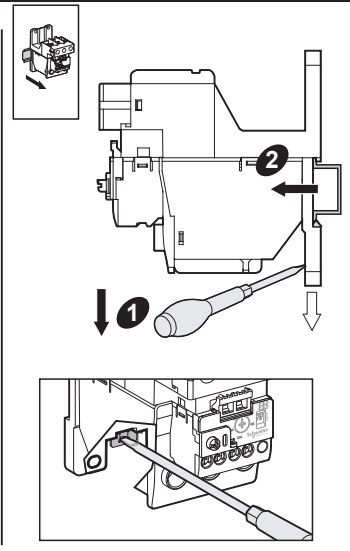
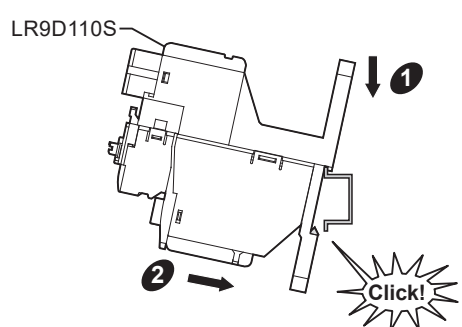
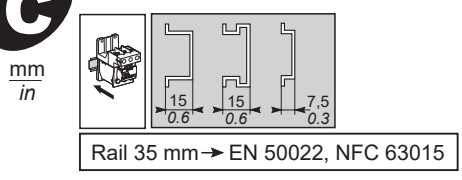

<p>⚠ WARNING / AVERTISSEMENT</p>	
<p>RISK OF FIRE OR ELECTRIC SHOCK (FOR CONTACTOR WITH UL HI-FAULT SHORT CIRCUIT CURRENT RATINGS ONLY) ■ The opening of the branch-circuit protective device may be an indication that a fault current has been interrupted. ■ To reduce the risk of fire or electrical shock, current-carrying parts and other components of the controller shall be examined and replaced if damaged. Failure to follow these instructions can result in death, serious injury, or equipment damage.</p>	<p>RISQUE D'INCENDIE OU D'ÉLECTROCUTION (SEULEMENT POUR CONTACTEUR AVEC UL HI-FAULT SCCR) ■ Le déclenchement du dispositif de protection de la dérivation peut signifier qu'un courant de fuite a été interrompu. ■ Pour réduire les risques d'incendie et de choc électrique, les pièces porteuses de courant et autres pièces de la commande doivent être examinées et remplacées au besoin. Si ces directives ne sont pas respectées, cela peut entraîner la mort ou des blessures graves ou des dommages matériels.</p>

A**LR9D01-32 + LC•D09-18****LR9D01-32 + LC•D25-38****B****LR9D01-32 + LAD7B205**

Rail 35 mm → EN 50022, NFC 63015

C**LR9D110S**

D

		LR9D01-32	LR9D110S
 95 - 96 97 - 98		0.8 N.m 7 lb-in	
		1...2.5 mm ² 18...14 AWG	
		6 mm 1/4 in	
 1/L1 - 3/L2 - 5/L3 2/T1 - 4/T2 - 6/T3		3.1 N.m 28 lb-in	9 N.m 80 lb-in
		2.5...16 mm ² 14...6 AWG	4...50 mm ² 10...1/0 AWG
		12 mm 7/16 in	

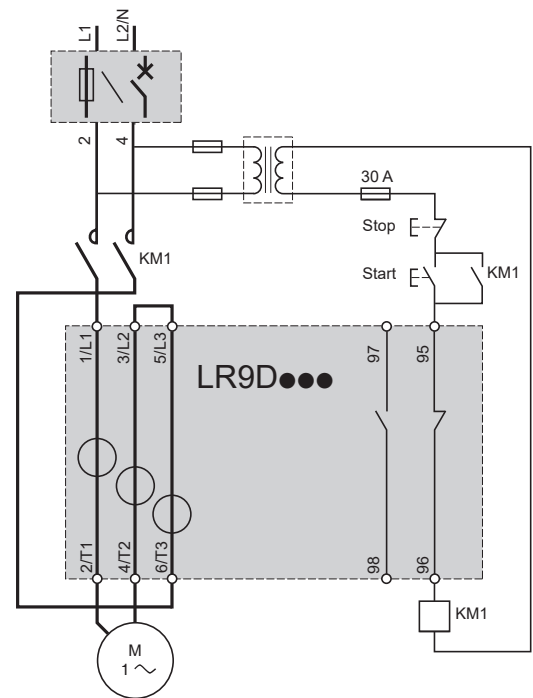
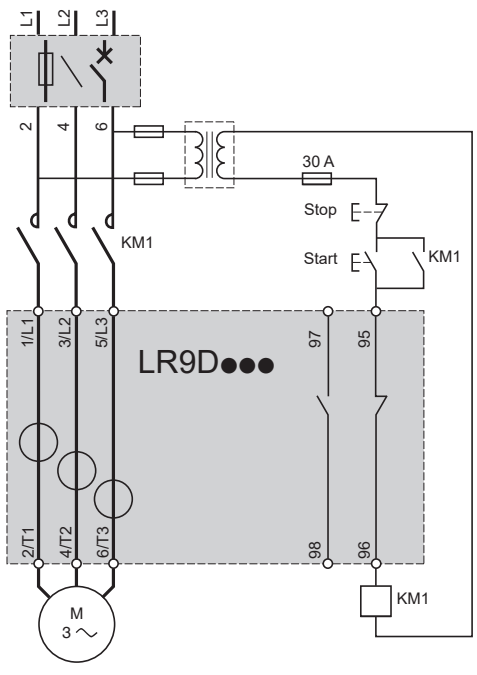

E

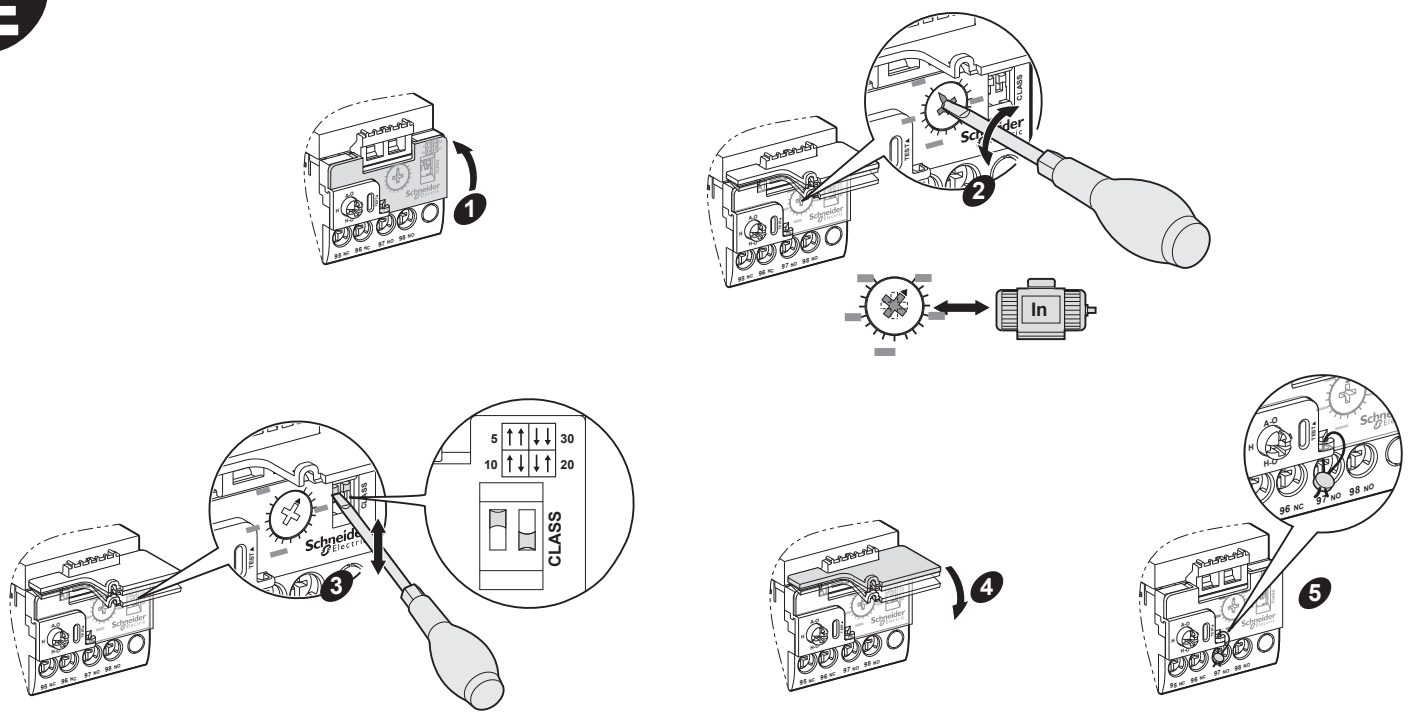

**▲ WARNING / AVERTISSEMENT / ADVERTENCIA / WARNUNG /
AVVERTIMENTO / ATENÇÃO / 警告 / ПРЕДУПРЕЖДЕНИЕ**

AUTOMATIC START HAZARD Motor connected to the circuit may start automatically in auto restart position. Failure to follow these instructions can result in death, serious injury, or equipment damage.	RISQUE DE DÉMARRAGE AUTOMATIQUE En mode de redémarrage automatique, il est possible que le moteur connecté au circuit démarre automatiquement. Si ces directives ne sont pas respectées, cela peut entraîner la mort ou des blessures graves ou des dommages matériels.	PELIGRO DE ARRANQUE AUTOMÁTICO Un motor conectado al circuito puede arrancar automáticamente cuando esté en la posición de re arranque automático. El incumplimiento de estas instrucciones puede causar la muerte, lesiones serias o daño al equipo.	GEFAHR EINES AUTOMATISCHEN STARTS Der an den Stromkreis angeschlossene Motor könnte in der Position für automatischen Neustart automatisch starten. Die Nichtbeachtung dieser Anweisungen kann Tod, schwere Verletzungen oder Sachschäden zur Folge haben.
PERICOLO AVVIO AUTOMATICO Il motore connesso al circuito può avviarsi automaticamente se in posizione riavvio automatico. Il mancato rispetto di queste istruzioni può provocare morte, gravi infortuni o danni alle apparecchiature.	PERIGO DE ARRANQUE AUTOMÁTICO O motor ligado ao circuito pode arrancar automaticamente na posição de re arranque automático. A não observância destas instruções pode provocar a morte, ferimentos graves, ou danos no equipamento.	自动启动危险 连接到电路中的电动机可能会在自动重新启动位置中自动重新启动。 不遵循上述说明可能导致人员伤亡或设备损坏。	ОПАСНОСТЬ АВТОМАТИЧЕСКОГО ЗАПУСКА Двигатель, подключенный к контуру, может запуститься автоматически в положении автоматического перезапуска. Несоблюдение этих инструкций может привести к смерти, серьезной травме или повреждению оборудования.



		en Operating mode	fr Mode de fonctionnement	es Modalidad de funcionamiento	de Betriebsmodus	it Modalità operativa	pt Modo de funcionamento	zh 运行模式	ru Рабочий режим
	H	Manual reset (factory setting)	Reset manuel (réglage usine)	Rearme manual (ajuste de fábrica)	Manuelles Reset (Werkseinstellung)	Reset manuale (impostazione di fabbrica)	Reposição manual (definição de fábrica)	手动复位 (出厂设置)	Ручной сброс (заводская настройка)
	H-O	Manual reset and motor stop	Reset manuel et arrêt moteur	Rearme manual y parada del motor	Manuelles Reset und Motorstopp	Reset manuale e arresto motore	Reposição manual e paragem do motor	手动复位和停止电机	Ручной сброс и останов двигателя
	A	Automatic reset	Reset automatique	Rearme automático	Automatisches Reset	Reset automatico	Reposição automática	自动复位	Автоматический сброс
	A-O	Automatic reset and motor stop	Reset automatique et arrêt moteur	Rearme automático y parada del motor	Automatisches Reset und Motorstopp	Reset automatico e arresto motore	Reposição automática e paragem do motor	自动复位和停止电机	Автоматический сброс и останов двигателя

	H	H-O	A	A-O
<p>Test / Test / Prueba / Test / Test / Teste / 测试 / Проверка</p>				
<p>Stop / Arrêt / Parada / Stopp / Arresto / Parar / 停止 / Стоп</p>	-		-	
<p>Reset / Reset / Rearme / Reset / Reset / Repor / 复位 / Сброс</p>				

Schneider Electric Industries SAS
 35, rue Joseph Monier
 CS 30323
 F - 92506 Rueil Malmaison Cedex

www.schneider-electric.com