

PRODUCT WARRANTY/12 MONTHS

The PDL 648TM Timer has a 12-month warranty from the date of purchase providing the unit is installed according to these instructions, local wiring regulations and Codes of Practice. This warranty is void on any unit that has been tampered with, or damaged by accident, improper operation or incorrect installation.

This guarantee is in addition to, and does not in any way affect the rights under the Consumer Guarantees Act 1993, if the ACT applies to the supply of this product and you are not acquiring the product for a business use. If the ACT applies and any term is inconsistent with the terms or requirements of the ACT that term shall be invalid without affecting the remaining terms of the warranty.

Note: Under the CGA 1993, Schneider Electric advises that this product does not contain user serviceable components thus spare parts and repair facilities are not available.

In the event of a warranty claim, the product must be returned to the point of purchase or direct to Australia/New Zealand distributors together with the proof of purchase.



648TM PRESET TIMER

Installation and consumer operating instructions for CAT 648TM Preset Timer.

FEATURES

Your PDL preset timer is an electronic device which enables your appliances to be powered for a restricted period of time, reducing energy consumption and limiting the danger of leaving appliances on for extended periods of time. The 648TM module is designed for compatibility with 600 series wallplates and features a simple one-button user interface. The time period (from 15s to 120min) and operation mode (on delay, on delay with manual override, or off delay) can be selected at installation. This timer may be used with loads of up to 3A at 240V a.c. (for larger loads use in conjunction with PDL modular relay 600RM - rated to 16A).



RATINGS

Operating Voltage230-240V a.c. @ 50Hz
 Load Capacity3A
 Operating Temperature-10 to 40°C
 Timer Range15sec to 120min
 Compliance StandardsAS/NZS3100, CISPR14

INSTALLATION INSTRUCTIONS

A. Determine Mode of Operation

The 648TM is capable of operating in a variety of unique configurations which are selected by setting the 'Mode' and 'Time' dials on the back of the timer during installation. There are three basic timer operating modes including (1) On Delay With Manual Override, (2) Off Delay, and (3) On Delay With No Manual Override. These are described as follows:

1. On Delay With Manual Override

In this mode, the unit can function in 'On Delay' or 'Manual Override' operation as detailed below.

1.1 On Delay operation

As shown in Figure 1 the load is initially OFF until the Start/Reset button is pressed for less than two seconds (A). Subsequently, the timer starts and the load is switched ON. The load will switch OFF when the Start/Reset button is pressed again (B) or the timer expires (C).

LED indicator will flash at half-second intervals while timer is active.

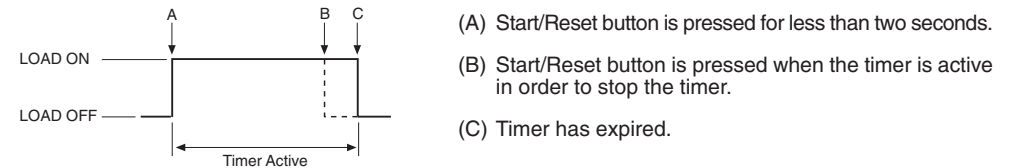

Figure 1: On Delay operation diagram



New Zealand Head Office:
 PO Box 15 355, New Lynn, Auckland, New Zealand
 Telephone +64-9-829 0490, Fax +64-9-829 0491
 www.pdl.co.nz



PDL Industries Australia Pty Ltd
 Locked Bag 5500, Baulkham Hills Business Centre
 Baulkham Hills NSW 2153 Australia
 Freephone 1300 735 266, Freefax 1300 735 329
 Telephone +61 29851 2666, Fax: +61 29851 2695
 www.pdl.com.au



1.2 Manual Override operation

As shown in Figure 2 the load is initially OFF until the Start/Reset button is pressed for two seconds or more (D). The load will switch OFF when the Start/Reset button is pressed (E).

LED indicator will remain steady ON while unit remains switched ON.

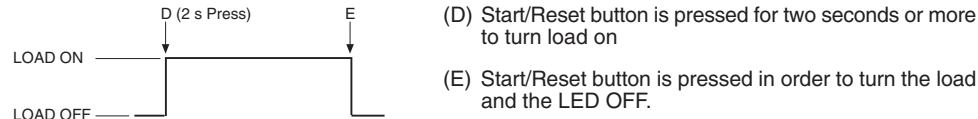

Figure 2: Manual Override operation diagram

2. Off Delay

As shown in Figure 3 the load is initially OFF until the Start/Reset button is pressed for less than two seconds (F). The timer will be activated if the Start/Reset button is pressed again (G). The load will switch OFF when the Start/Reset button is pressed for the third time (H) or the timer has expired (I).

LED indicator will flash at half-second intervals while timer is active.

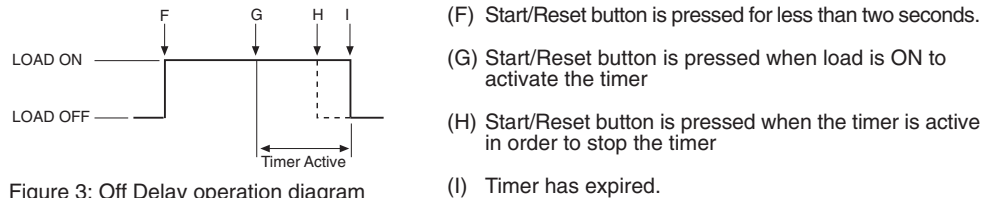

Figure 3: Off Delay operation diagram

3. On Delay With No Manual Override

For a description of this operation, see section (1) above, but disregard part (1.2).

B. Select Timer Settings

The back of your 648TM timer has two setting dials, labelled 'MODE' and 'DELAY' respectively. Use the Timer Setting Table below to determine the position of these dials, which will configure the timer to suit your needs.

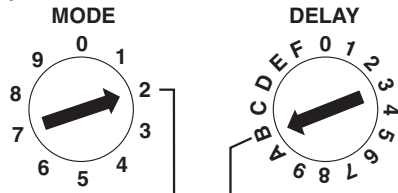

EXAMPLE
In this example, the timer is set to function in Off Delay mode (D2) with a Timer Active period of 40 minutes (see operation diagram, Figure 3).

Please note, all times in table are in minutes.

- 0.25min = 15sec;
- 0.5min = 30sec.

Timer Setting Table

MODE Setting	MODE	DELAY Settings (displayed in minutes)															
		0	1	2	3	4	5	6	7	8	9	A	B	C	D	E	F
0	D1	0.25	0.5	1	2	5	10	15	20	25	30	35	40	45	50	55	60
1	D1	60.25	60.5	61	62	65	70	75	80	85	90	95	100	105	110	115	120
2	D2	0.25	0.5	1	2	5	10	15	20	25	30	35	40	45	50	55	60
3	D2	60.25	60.5	61	62	65	70	75	80	85	90	95	100	105	110	115	120
4	D3	0.25	0.5	1	2	5	10	15	20	25	30	35	40	45	50	55	60
5	D3	60.25	60.5	61	62	65	70	75	80	85	90	95	100	105	110	115	120

D1 = Delay from switch on, with manual override
D2 = Delay from switch off
D3 = Delay from switch on, no manual override

C. Complete the Assembly

WARNING: Before wiring, ensure the supply is disconnected at the distribution board and study the connection diagram before terminating wires. Be careful not to connect the supply line to any terminal other than indicated in the diagram and on the product. Connect wires to the product as indicated in the wiring diagram.

1. Select the appropriately coloured front cover from the enclosed assortment and snap onto the front of the timer as shown in figure 4.

IMPORTANT: Front cover must be installed to avoid potential safety hazards.

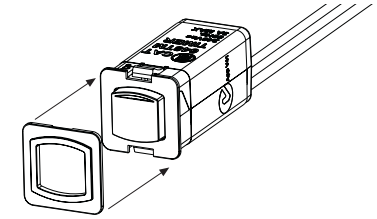

Figure 4: Front Cover Installation

2. Terminate wires as indicated in the wiring diagram (see figure 5)

NOTE: The timer module is not surge protected. Protection from power surges may be accommodated by installing an external surge protection device.

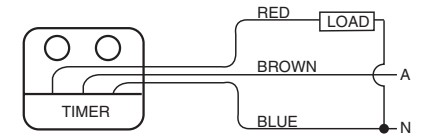

Figure 5: Wiring Diagram

3. Snap unit into a modular mounting plate as shown in figure 6.

IMPORTANT: Mounting in a 4, 5, or 6 aperture grid plate with a PDL 144 flush box requires a minimum wall cladding thickness of 10mm.

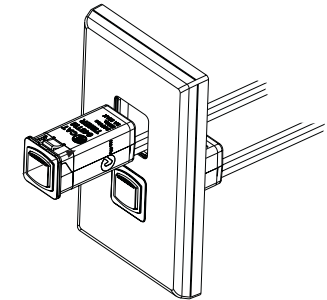

Figure 6: Mounting Timer

OPERATING INSTRUCTIONS

Your timer can operate in one of two basic modes that are set at installation:

On Delay Mode

1. Press button once to energise circuit and start timer. The unit will be switched ON for the time prescribed, then automatically switch OFF.
2. Press button a second time if you wish to switch OFF unit before timer expires.
3. Using the Manual Override feature (this feature may be deactivated at installation):
 - You may manually override the timer to switch ON unit indefinitely by pressing and holding the button for two seconds.
 - Press button again to switch OFF unit.

Off Delay Mode

1. Press button once to energise circuit. The unit will remain switched ON indefinitely.
2. Press button a second time to start timer. From this button press, the unit will remain switched ON for the time prescribed, then automatically switch OFF.
3. Press button a third time if you wish to switch OFF unit before timer expires.

NOTE:

1. In the event of power loss, upon power resumption the timer will start-up in the initial LOAD OFF state.
2. Timer cannot be operated via a remote switch.