

# ABL1A01

reversible mounting bracket - for regulated switch mode power supply

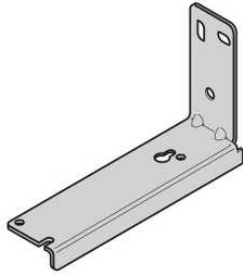

## Main

Range of product	Phaseo
Accessory / separate part designation	Reversible mounting bracket
Accessory / separate part type	Bracket
Accessory / separate part category	Mounting and fixing accessories
Product compatibility	ABL1REM12050 ABL1REM24025 ABL1REM24042 ABL1REM24062 ABL1REM24100 ABL1RPM12083 ABL1RPM24042 ABL1RPM24062 ABL1RPM24100
Accessory / separate part destination	Mounting on the back of cabinet of power supply
Quantity per set	Set of 5

## Complementary

Product weight	0.085 kg
----------------	----------

## Environment

## Dimensions

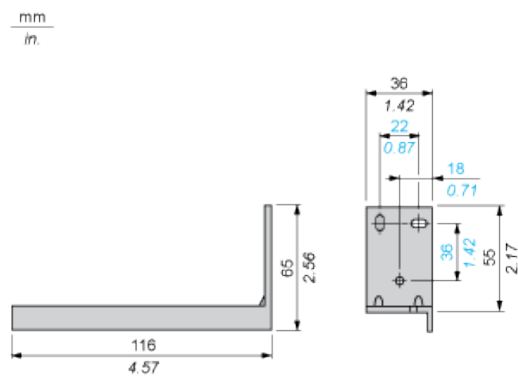

The information provided in this documentation contains general descriptions and/or technical characteristics of the performance of the products contained herein. This documentation is not intended as a substitute for and is not to be used for determining suitability or reliability of these products for specific user applications. It is the duty of any such user or integrator to perform the appropriate and complete risk analysis, evaluation and testing of the products with respect to the relevant specific application or use thereof. Neither Schneider Electric Industries SAS nor any of its affiliates or subsidiaries shall be responsible or liable for misuse of the information contained herein.